

EXPERIMENTAL INVESTIGATION OF HEAT TRANSFER UNDER CONDITIONS
OF LAMINARIZATION OF TURBULENT FLOWS

V. G. Zubkov

UDC 533.6

The results of an experimental investigation of the temperature in model nozzles of an experimental setup under conditions of laminarization of turbulent flows are presented.

Introduction. In many experimental investigations of turbulent flows driven by a negative pressure gradient it is observed that the characteristics of heat transfer and friction are significantly different from the corresponding values for turbulent flows [1, 2]. The greater the acceleration of the flow the larger are the deviations of the integral characteristics of the flow as well as the profiles of the average velocity and temperature from the universal relations for a turbulent flow regime toward dependences corresponding to a laminar regime. This phenomenon is called laminarization of turbulent flows.

The conditions under which laminarization appears can be estimated, to a first approximation, with the help of the acceleration parameter $K = \frac{v}{U_\infty^2} \frac{dU_\infty}{dx}$, which characterizes the degree of acceleration of the flow. It has been established that the parameters of heat transfer start to decrease in flows in which $K > K_{cr} = 2 \cdot 10^{-6}$. However this parameter is a local parameter, so that it does not reflect many important features of the flow, for example, such as the conditions preceding laminarization. With its help it is virtually impossible to estimate the quantitative aspect of the phenomenon.

The difficulty of predicting reliably the onset of laminarization and the degree to which it affects the integral characteristics of heat transfer and friction makes it necessary, at the present time, to confine the study to accumulation of experimental data in which this effect is observed. This is all the more important for flows in nozzles, since any method of reducing heat transfer in the region of the critical cross section simplifies the problem of cooling them.

1. Experimental Apparatus. In this paper we present the results of experiments on the measurement of heat fluxes in two model supersonic nozzles. The tests were performed with the help of a solid-fuel gas generator with a constant flow rate (Fig. 1). The form of the charge ensures that the combustion surface is constant throughout the time that the gas generator is in operation. The products of combustion contain virtually no condensed phase and their stagnation temperature is equal to 2160 K.

The main object of investigation is a replaceable nozzle unit. The nozzle unit is a compound unit consisting of 1.5 mm thick disks (M1 copper). The thermal resistance of the contact between the disks makes it possible to regard each disk as a circular calorimeter. To measure the temperature, two thermocouples are caulked into the disks at distances of 0.015 and 0.025 m from the inner surface.

For the investigations we used two types of conical nozzles, which differ from one another by the aperture half-angles in the sub- and supercritical regions (Fig. 2). The choice of configuration of the inner contour ensures that acceleration parameters of $5 \cdot 10^{-6}$ and $2.5 \cdot 10^{-6}$ are achieved in the subsonic part for the nozzles Nos. 1 and 2, respectively.

2. Solution of the Inverse Problem of Heat Conduction. To determine from the known temperature of the structure $T(r_e, \tau)$ the heat fluxes $q(r_o, \tau)$ acting on the surface of the nozzle units the inverse problem of heat conduction is solved. The one-dimensional formulation of the problem is studied. The data on the thermophysical properties of the material of the structure as a function of the temperature, which are necessary for solving the problem, were taken from [3].

Moscow Automobile Manufacturing Institute. Translated from *Inzhenerno-fizicheskii Zhurnal*, Vol. 60, No. 2, pp. 181-185, February, 1991. Original article submitted March 6, 1990.

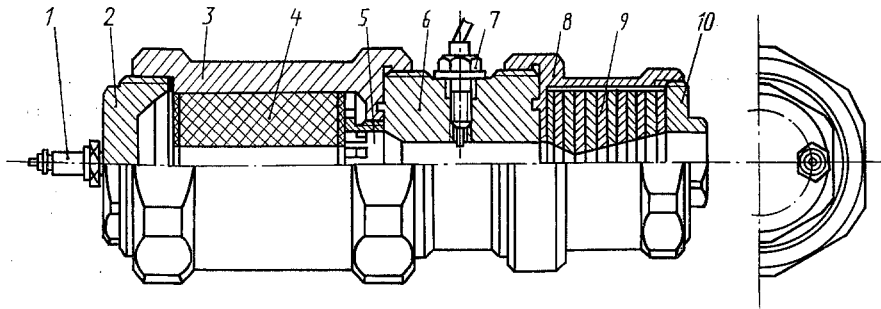

Fig. 1. Diagram of the experimental apparatus (the pressure gauge and the safety valve are not shown): 1) spark plug; 2) cover; 3) housing; 4) charge with metal-cladded ends; 5) unit for attaching the charge; 6) reducer; 7) thermocouple; 8) housing of the nozzle unit; 9) calorimetric rings; 10) lock nut.

In this investigation the nonlinear inverse problem of heat conduction is solved by the method of regularization based on the algorithm proposed in [4, 5]. The essence of this algorithm consists of the following. Let us assume that we have some method for solving the direct nonlinear problem of heat conduction which permits determining for a fixed heat load the nonstationary temperature field arising in the cross section containing the control point r_e — "the temperature sensor." In the segment $[0, \tau_k]$, characterizing the time interval in which the temperature of an interior point of the body changes, an interval $\Delta\tau_N = \tau_{N-l} - \tau_{N-1}$ of length $l\Delta\tau$ ($1 \leq N \leq m-l+1$, $l > 0$ is an integer number of segments $\Delta\tau$ in the linearization interval) is singled out. At each time $\tau_i = i\Delta\tau$ ($0 \leq i \leq l$) the temperature at the experimental point is known. Within the time interval $\Delta\tau_N$ it is assumed that the thermophysical parameters are functions of the coordinates and are determined by the temperature $\psi = T_{N-1}$ at the time $\tau = \tau_{N-1}$, corresponding to the left boundary of the interval $\Delta\tau_N$.

For such assumptions it is shown in [6] that starting from the principle of superposition and a unit heat load in the final time interval $\Delta\tau_N$, the change in the temperature at the experimental point can be described by a system of linear algebraic equations with a triangular matrix:

$$\sum_{j=1}^J \varphi_j^N q_j = f_J^N, \quad (1)$$

where $j = 1$ corresponds to $n = N$ and $J = 1, 2, \dots, l$;

$$\varphi_j^N = T(r_e)_j|_{q_{j-1}=1; q_{j>1}=0} - T(r_e)_j|_{q_{j\geq 1}=0}, \quad (2)$$

$$f_J^N = T^e(r_e)_J - T(r_e)_J|_{q_{j\geq 1}=0}; \quad (3)$$

q_j is the value of the heat flux, to be determined, in the j -th segment $\Delta\tau$ of the interval $\Delta\tau_N$; $T(r_e)_j|_{q_{j\geq 1}=0}$, $T(r_e)_j|_{q_{j-1}=1; q_{j>1}=0}$ are the computed values of the temperature at the location of the thermocouple, which are obtained with the initial condition $\psi = T_{N-1}$ and boundary conditions $q_1 = q_2 = \dots = q_j = 0$ and $q_1 = 1, q_2 = q_3 = \dots = 0$, respectively; $T^e(r_e)$ is the experimental value of the temperature.

The temperature at the experimental points is determined by solving the direct problem of heat conduction with the initial condition $\psi = T_{N-1}$, corresponding to the time $\tau_i = \tau_{N-1}$.

Because the system (1) is improperly posed, owing to the approximate values of $T^e(r_e)$, the system is solved by the method of regularization [7]. For this system of equations the regularizing functional is chosen in the form

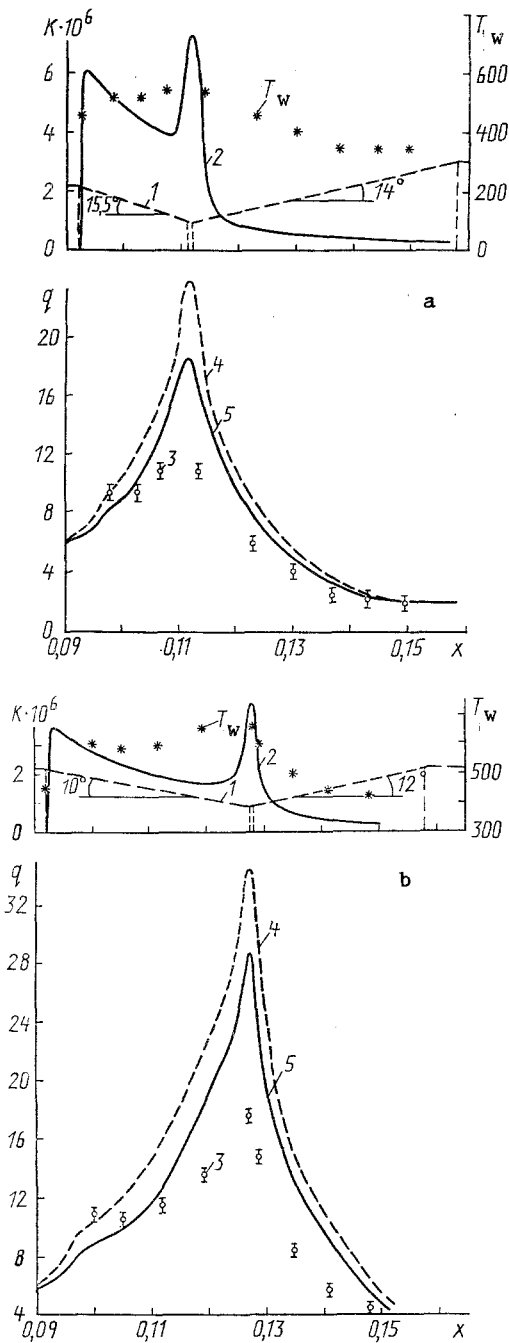

Fig. 2. The experimental data for the nozzles No. 1 (a) ($p_{00} = 3.5 \cdot 10^6$ N/m², $d_{cr} = 0.01$ m) and No. 2 (b) ($p_{00} = 6 \cdot 10^6$ N/m², $d_{cr} = 0.0089$ m): 1) nozzle contour; 2) acceleration parameter; 3) specific heat flux; 4) calculation by the method of [9]; 5) calculation by the method of [10]. T_{st} , K; q , MW/m²; x , m.

$$\Phi[q_j; \alpha] = \sum_{j=1}^l \left(\sum_{i=1}^j \varphi_i^N q_j - f_j^N \right)^2 + \alpha \sum_{i=0}^l (q_{i+1} - q_i)^2. \quad (4)$$

The values sought for the heat fluxes into the wall q_j are determined by minimizing the functional $\Phi[q_j; \alpha]$. The best approximation to the solution is chosen according to the principle of residuals [8]. The value of the regularization parameter α is determined by minimizing the quantity

$$\Delta = \left| \left[\sum_{j=1}^l \left(\sum_{i=1}^J \Phi_i^N q_j - f_j^N \right)^2 \right]^{1/2} - \delta_e \right|,$$

where δ_e is the error characterizing the accuracy of the measurement of the experimental value of the temperature at the control point r_e of the body. Since the error in determining the temperature did not exceed ± 0.5 K, the heat flux is calculated with an accuracy of up to $\pm 5-10\%$.

The values of the heat flux into the wall of the nozzle unit at specific times for each control point are determined based on the algorithm, given above, for solving the inverse problem of heat conduction. In spite of the spread in the values of the specific heat flux, there is a certain regularity to its change in time. By averaging the results of analysis over several time intervals it is possible to obtain the distribution of the heat flux along the nozzle surface over which the gas flows. This procedure is legitimate because the temperature at the point of measurement is determined by the total effect of the heat flux from the onset of heating up to the moment under study.

3. Experimental Results. Figure 2 shows, together with the profiles of the nozzle units under study, the distribution of the heat flux q and the surface temperature T_{st} for the time $\tau = 2$ sec. The figure also shows the values of the acceleration parameter K , calculated under the assumption that the motion of the gas is one-dimensional. In the first case, for nozzle No. 1 with a truncated converging part, the gas flow reaches high degrees of acceleration. The acceleration parameter along the entire subcritical part is two to three times higher than the value of K_{cr} , while for the nozzle No. 2 $K \sim K_{cr}$.

As follows from the graphs, the maximum heat flux in both cases is located in the region of the critical section of the nozzle. The second maximum (significantly smaller) is observed near the cylindrical gas duct. It is especially noticeable for a nozzle with an elongated entrance (Fig. 2b). In this section of the setup the intensity of heat transfer is significantly affected by flow effects produced by the fact that the entry into the converging part of the nozzle is not specially shaped and by the sharp change in the temperature of the wall.

Comparing the experimental values of the heat fluxes with the results of the corresponding calculations performed by the author using the methods described in [9, 10] shows that the intensity of heat transfer drops significantly in accelerated flows. In addition, this drop is observed not only in the zone where the acceleration parameter exceeds its critical value, but also far downstream after the acceleration parameter drops. This is especially noticeable for nozzle No. 1, in which the aperture half-angles of the converging part are large.

In calculations performed by the methods of [9, 10], radiative heat transfer is neglected, since in the case at hand the radiative heat flux is equal to not more than 5% of the convective heat flux over the entire length of the nozzle. The stagnation temperature was chosen as the determining temperature in the calculations.

Conclusions. The above-presented results of an investigation of heat transfer in model nozzles show that the laminarization effect exists for large degrees of flow acceleration. It was observed that the experimental values of the heat flux drop by 50% relative to the calculation for the turbulent flow regime. In spite of the fact that the decrease in heat transfer is observed for both contours, the use of truncated nozzles with a converging part having large aperture half-angles results in a stronger effect.

NOTATION

x , coordinate along the flow; U_∞ velocity of the incident flow; q , specific heat flux; T , temperature; T_e , experimental value of the temperature at the control point; T_{st} , temperature of the surface in the flow; K , acceleration parameter; ν , kinematic viscosity; τ , time; τ_c , control time; $\Delta\tau$ and $\Delta\tau_N$, time intervals; r_e , coordinates of the control point at which the temperature is determined; r_0 , coordinates of the nozzle wall; Φ_i , f , functions of the temperature at the location of the thermocouple; $\Phi[q_j; \alpha]$, regularizing functional; α , regularization parameter; N , number of the linearization interval; m , total number of time segments $\Delta\tau$, segment $[0; \tau_c]$; p_{00} , pressure in the combustion chamber; and d_{cr} , diameter of the critical cross section of the nozzle.

LITERATURE CITED

1. L. G. Bek, R. F. Kaffel, and P. F. Mess'e, *Teploperedacha*, 92, No. 3, 29-40 (1970).
2. P. M. Moretti and W. M. Kays, *Int. J. Heat Mass Transfer*, 8, Pt. 9, 1187-1202 (1965).
3. V. S. Chirkin, *Thermophysical Properties of Materials* [in Russian], Moscow (1959).
4. O. M. Alifanov, *Inzh.-Fiz. Zh.*, 25, No. 2, 363-370 (1973).
5. O. M. Alifanov, *Inzh.-Fiz. Zh.*, 26, No. 1, 116-121 (1974).
6. J. V. Beck and H. Wolf, "The nonlinear inverse heat conduction problem," ASME Paper No. HT-40 (1965).
7. A. N. Tikhonov, *Dokl. Akad. Nauk SSSR*, 151, No. 3, 501-504 (1963).
8. V. A. Morozov, *Zh. Vychisl. Mat. Mat. Fiz.*, 8, No. 2, 295-309 (1968).
9. M. V. Dobrovolskii, *Liquid-Fuel Rocket Motors* [in Russian], Moscow (1968).
10. D. R. Bartz, *Jet Propulsion*, 27, Pt. 1, 49-51 (1957).